

Spectrum® 2050

Issued March 2010 • Index No. PC/7.0

Air Plasma
Cutting and Gouging 

Quick Specs

Industrial Applications

Construction
Maintenance/Repair
Fabrication

Processes

Air Plasma Cutting
and Gouging

Rated Output

55 A at 110 VDC,
60% Duty Cycle, 3-Phase
55 A at 110 VDC,
50% Duty Cycle, 1-Phase

Cutting Capability

Rated: 7/8 in (22.2 mm)
Sever: 1-1/8 in (28.6 mm)

Weight

With torch: 86 lb (39 kg)

Required Input Pressure/Flow

6 SCFM (170 L/min) at
90 PSI MIN (621 kPa)
120 PSI MAX (828 kPa)

The Power of Blue.®

Auto-Line™ automatically links the Spectrum® 2050 to any primary input voltage from 208 to 575 V, single- or three-phase, 50 or 60 Hz.

Consumables storage compartment provides convenient access to consumables and parts.

Wind Tunnel Technology™ prevents abrasive dust and particles from damaging internal components. Also, the **Fan-On-Demand™** cooling system only operates when needed. In dirty or dusty environments, this feature reduces the amount of airborne dust/dirt pulled through the unit.

Postflow cooling circuit cools consumables and torch with postflow air after you release the trigger. This feature extends life of the torch and consumables.

ICE-55C torch offers improved plasma flow characteristics for increased cutting speeds and longer consumable set life.

The ICE-55C torch includes a **drag shield** that attaches to the cup and holds the tip 1/8 in (3.2 mm) off the workpiece. This permits the operator to drag the torch on the workpiece while cutting at full output, which increases operator comfort and makes template cutting easier.



Spectrum Plasma Cutters offer reliability and performance that others can't match! See more at MillerWelds.com/reliable

Comes Complete With:

- ICE-55C hand-held torch with 25 ft (7.6 m) or 50 ft (15.2 m) cable, or ICE-55CM machine-held torch with 50 ft (15.2 m) cable. Extra consumables supplied
- Heavy-duty work clamp with 25 ft (7.6 m) or 50 ft (15.2 m) cable
- 10 ft (3 m) power cord

A standard feature, the **pilot arc switch** in expanded metal mode allows operator to cut grates, chain link fence, and other perforated metals without retriggering the gun.

Portable, easy-to-carry unit weighs only 86 lb (39 kg).

Starts without high-frequency so it will not interfere with or damage controls or computers.

Built-in gas/air filter/regulator is housed inside the power source for protection from transportation damage. A standard air connection is also provided on the back panel for easy gas or air hookup.

Can be powered by any Miller engine drive with generator power (e.g. Bobcat™) or equivalent competitive equipment. See page 3 for engine drive compatibility and recommended settings.

TRUE BLUE®
3YR. WARRANTY

Power source is warranted for 3 years, parts and labor.
ICE torch is warranted for 1 year, parts and labor.

MADE IN **USA**
APPLETON, WI



Miller Electric Mfg. Co.
An Illinois Tool Works Company
1635 West Spencer Street
Appleton, WI 54914 USA

Equipment Sales US and Canada
Phone: 866-931-9730
FAX: 800-637-2315
International Phone: 920-735-4554
International FAX: 920-735-4125

Web Site
www.MillerWelds.com



Specifications (Subject to change without notice.)



Rated Output	Max. Open-Circuit Voltage	Amps Input at Rated Output									Plasma Gas	Dimensions	Weight with Torch
		208 V	230 V	380 V	400 V	415 V	460 V	575 V	KVA	KW			
55 A at 110 VDC, 60% duty cycle, 3-Phase	280 VDC	21	20	10	10	10	9	8	7.6	7.4	Air or Nitrogen only	H: 17 in (432 mm) W: 12-1/2 in (318 mm) D: 20-3/4 in (527 mm)	Net: 86 lb (39 kg) Ship: 93.5 lb (42.4 kg)
55 A at 110 VDC, 50% duty cycle, 1-Phase		36	33	—	—	—	16	13	7.5	7.4			

Note: For any single- or three-phase voltage from 208 V to 575 V, the Amps Input at Rated Output is the same for 50 or 60 Hertz input power.

Mild Steel Cutting Capability (Thickness to scale.)

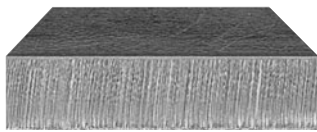

1/2 in (12.7 mm) at 27 IPM
Maximum Sever cut of 1-1/8 in (28.6 mm) at 3 IPM



7/8 in (22.2 mm) at 10 IPM

Rated cut capacity is based on traveling approximately 10 inches per minute to achieve a steady, precise cut. This is the key rating that should meet or exceed your typical cutting thickness requirements.

Note: Recommended maximum piercing capacity for hand-held applications is 7/16 in (11 mm).

Maximum Sever cut of 1-1/8 in (28.6 mm) a 3 IPM

For aluminum and other metals with high thermal conductivity, cutting capabilities will be derated as much as 30%.

Control Panel

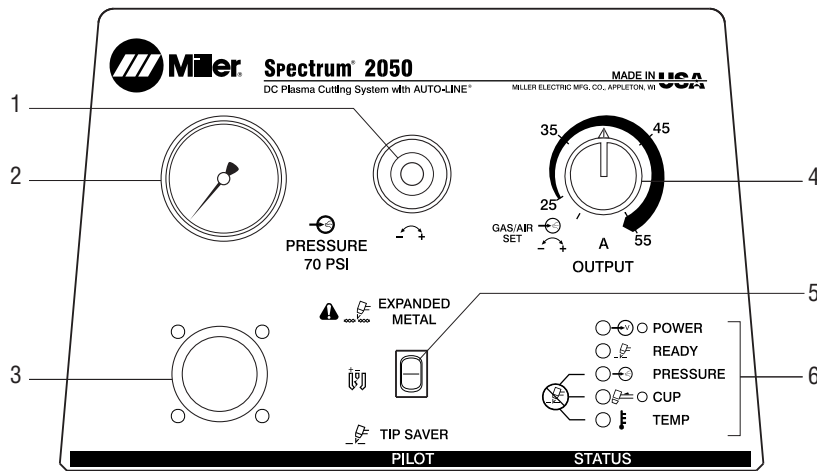

- Gas/Air Pressure Adjustment Control
- Gas/Air Pressure Gauge
- Torch Connection Receptacle
- Output Control
- Pilot Arc Mode Switch
- Status and Troubleshooting Lights

Cutting Performance

To determine the maximum rated cutting thickness of mild steel, follow the line from the 10 IPM (inches per minute) point on the cutting chart. The point at which this line intersects the cutting curve determines the maximum recommended production cutting thickness of the unit.

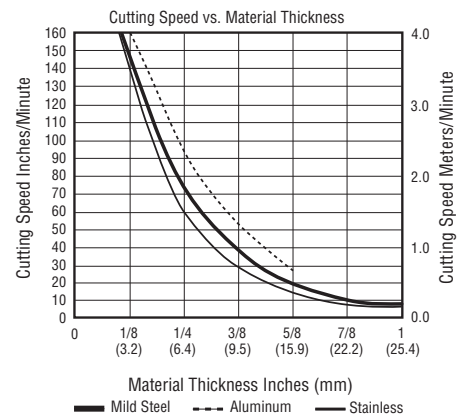

Note: The rating is based on 10 IPM because this is the minimum speed at which the operator achieves a smooth, steady cut when using a hand-held torch.

Engine Drive Compatibility

Equipment	Generator Power	Steel Quality Cut (Approximate)	Spectrum Output Amp Setting
Bobcat™, Trailblazer®	11 kW	3/4 in	50 A, 240 V, full KVA plug
PipePro® 304, Big Blue® 300 Pro	12 kW	3/4 in	55 A, 240 V, full KVA plug
Big 40® CC/CV	15 kW (optional)	3/4 in	55 A, 240 V, full KVA plug
Big Blue® 500 CC/CV	20 kW (optional)	5/8 in	55 A, 240 V, full KVA plug

Note: Includes Spectrum 2050 models manufactured after (and including) serial number KJ283702. LP powered machines need to be derated 15%.

Genuine Miller Accessories



No. 30B Economy Running Gear and Cord Wrap #300 511

Economical running gear with angle for easy front panel access provides storage for gloves and tools.



Protective Cover #195 271

Mildew-resistant, odor-free, waterproof cover protects your machine's finish.



Female Receptacle



Adapter Cord, Full KVA #300 517 Field NEMA 14-50P to NEMA 6-50R. Adapts engine drive 120/240 V plug to Spectrum® 240 V plug.



RTI Filter and Bracket #300 491

Filter/dryer with automatic drain removes water, dirt and oil as small as one micron with 99.9% efficiency. Can be mounted on plasma cutter or on wall. Install as close as possible to point of air consumption.

Miller Service Parts Accessories

The following accessories must be ordered from Miller Service Parts.

RTI Replacement Filter Element #212 771
Replacement filter for #300 491.

Remote Pendant Control #180 605
Provides remote start and stop of the arc for the ICE-55CM machine-held torch.



ICE-55C Consumable Kit #222 941

Consumable kit includes 4 standard electrodes, 4 standard tips, 2 ext electrodes, 2 ext tips, 1 gouge tip, 1 gouge shield, 1 drag shield, 1 retaining cup, 3 o-rings and silicone grease.



Plasma Standoff Roller Guide #194 883

Helps maintain recommended standoff distance to maximize cutting performance and improve tip life.



Plasma Circle-Cutting Guide #195 981

Cut straight lines or circles up to 12 inch diameter with ease.



Suction/Magnetic Pivot Base #195 979

Add this to your cutting guide for convenient attachment to all flat surfaces. The extended arm accommodates holes up to 30 inch diameter.



Torch Cable Covers

#231 867 25 ft (7.6 m)
#231 868 50 ft (15.2 m)



240 V Plug #119 172

For connection to Bobcat, Trailblazer or Hobart Champion 10,000 with a minimum of 8 KVA auxiliary power.



In-Line Air Filter Kit #228 926

Mounts to the back of the Spectrum® 375 X-TREME™, 375, 625 X-TREME™, and 875. Includes male and female 1/4 in NPT quick disconnect fittings and hose for easy on/off connection. The replaceable filter element filters to .85 microns for removal of 99.9% of water, dirt and oil.

In-Line Air Filter Replacement Element #228 928

Includes 1 replacement filter for in-line filter #228 926.



MIG Gloves

#227 821 Small
#227 822 Medium
#227 823 Large
#227 824 X-Large
For medium-duty MIG welding and metalworking tasks. Combination of

durable top grain cowhide palm and abrasion-resistant pig split back sewn with Kevlar® thread.



Metalworker Gloves

#227 817 Small
#227 818 Medium
#227 819 Large
#227 820 X-Large
Designed for the daily demands of the metalworker and material handler. Padded,

goatskin palm with textured G-Grip™ patch for excellent grip. Neoprene wrist with Velcro® closure for improved fit. NOT intended for use while welding.

Replacement Torch and Consumables

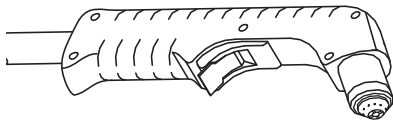

ICE-55C Hand-Held Torch
#193 347 25 ft (7.6 m)
#193 348 50 ft (15.2 m)



ICE-55CM Machine-Held Torch
#193 349 50 ft (15.2 m)

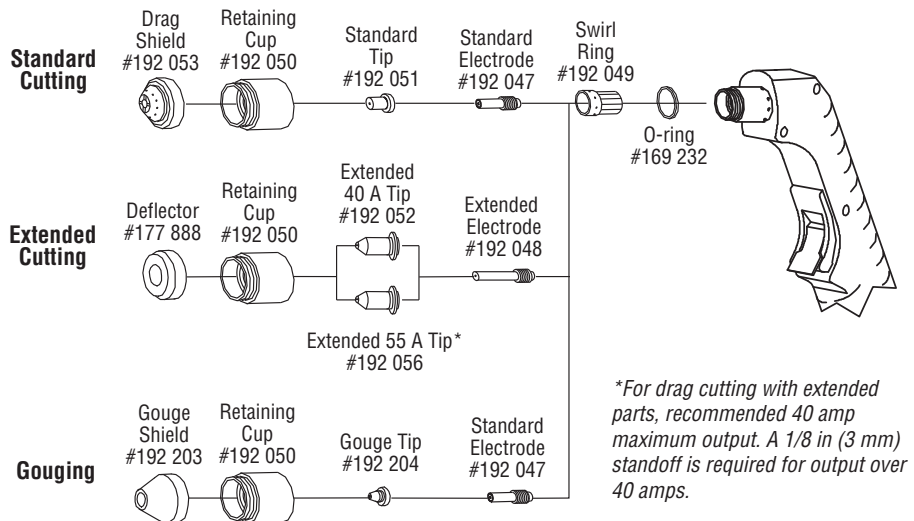

*For drag cutting with extended parts, recommended 40 amp maximum output. A 1/8 in (3 mm) standoff is required for output over 40 amps.

Ordering Information

Power Source and Options	Stock No.	Description	Qty.	Price
Spectrum® 2050 Single-/three-phase, 208–575 VAC, 50/60 Hz <i>Note: Each Spectrum unit includes extra consumables (2 standard electrodes, 2 standard tips, 1 ext. electrode, 1 ext. tip and 1 deflector).</i>	#903 777-01-2* #903 777-01-3* #903 777-02-2*	With ICE-55C, 25 ft (7.6 m) hand-held torch With ICE-55C, 50 ft (15.2 m) hand-held torch With ICE-55CM, 50 ft (15.2 m) machine-held torch <i>(Machine torch package includes remote pendant control #180 605)</i>		
Replacement Torches				
ICE-55C Hand-Held Torch	#193 347 #193 348	25 ft (7.6 m). <i>Order from Miller Service Parts</i> 50 ft (15.2 m). <i>Order from Miller Service Parts</i>		
ICE-55CM Machine-Held Torch	#193 349	50 ft (15.2 m). <i>Order from Miller Service Parts</i>		
Consumables		See above. <i>Order from Miller Service Parts</i>		
Accessories				
No. 30B Economy Cart	#300 511			
Protective Cover	#195 271			
Adapter Cord, Full KVA	#300 517	Adapts engine drive 120/240 V plug to Spectrum® 240 V plug		
RTI Filter and Bracket	#300 491			
RTI Filter Replacement Element	#212 771	For RTI filter #300 491. <i>Order from Miller Service Parts</i>		
Remote Pendant Control	#180 605	<i>Order from Miller Service Parts</i>		
ICE-55C Consumable Kit	#222 941	See page 3 for contents. <i>Order from Miller Service Parts</i>		
Plasma Standoff Roller Guide	#194 883	<i>Order from Miller Service Parts</i>		
Plasma Circle-Cutting Guide	#195 981	<i>Order from Miller Service Parts</i>		
Suction/Magnetic Pivot Base	#195 979	<i>Order from Miller Service Parts</i>		
Torch Cable Covers		See page 3. <i>Order from Miller Service Parts</i>		
240 V Plug	#119 172	<i>Order from Miller Service Parts</i>		
In-Line Air Filter Kit	#228 926	<i>Order from Miller Service Parts</i>		
In-Line Air Filter Replacement Element	#228 928	<i>Order from Miller Service Parts</i>		
MIG/Metalworker Gloves		See page 3. <i>Order from Miller Service Parts</i>		

Date: Total Quoted Price:

 Certified by Canadian Standards Association to both Canadian and U.S. Standards.



Distributed by: